

MODERN BEDACHT

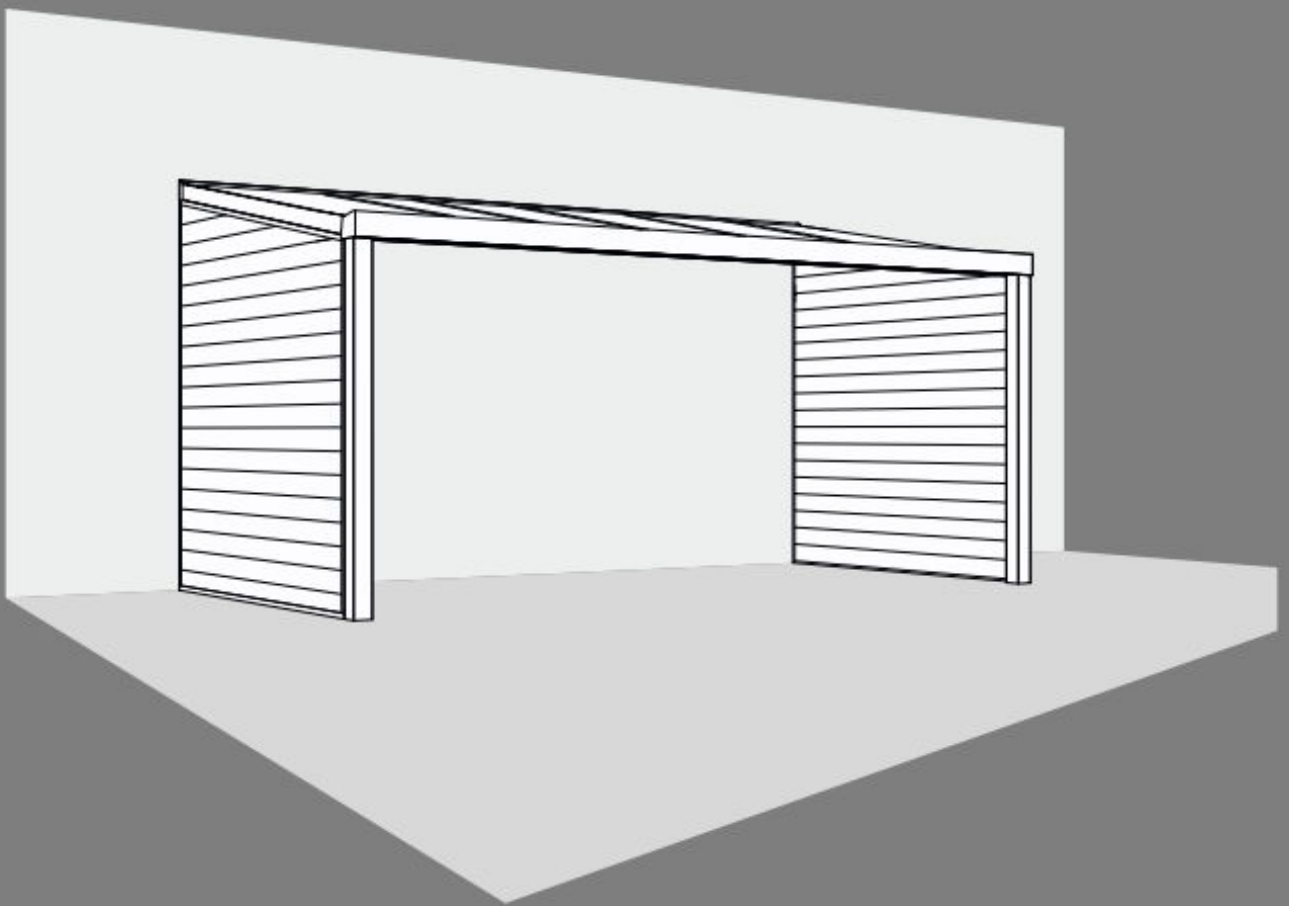

MONTAGE ANLEITUNG
ALUMINIUM SEITENWAND

MODERNBEDACHT

Aluminium-Wandsystem

Aluminium Wall System

Index

index

3

Sicherheitshinweise

safety instructions

4

Legende

legende

7

Werkzeuge

tools

8

Teile

parts

9

Konstruktion Übersicht

construction overview

10

Montage

assembly

12

© 2025 Beghler BV. All rights reserved.

This manual is copyrighted and may not be copied, reproduced, distributed, or used in any way without prior written permission from Beghler BV. It is intended solely for authorized users and may not be commercially exploited or modified.

While this manual has been compiled with care, Beghler BV accepts no liability for any errors or inaccuracies. Use of the information is at your own risk.

safety instructions

1

English

Safety Instructions – Aluminium Wall System

Article 1 – General Provisions

- 1.1 Read this manual carefully before installing or using the aluminium wall system (hereinafter: the 'Product'). Incorrect use may result in material damage or personal injury and void the warranty.
- 1.2 Retain this manual and provide it upon transfer of the Product.
- 1.3 Contact your sales representative for unanswered questions. If you lack installation experience, consult a professional.
- 1.4 Illustrations are for reference only and may differ from the actual Product.
- 1.5 This manual is protected by copyright and may not be reproduced or distributed without prior written consent.
- 1.6 Keep unassembled components out of reach of children.

Article 2 – Intended Use

- 2.1 The Product is a fixed aluminium wall designed for side mounting on a patio cover.
- 2.2 Use for other applications is at the user's own risk. The manufacturer accepts no liability for any resulting damage.
- 2.3 The maximum wind resistance is 55,86 kg/m². Consult an expert when placing the Product in open spaces.
- 2.4 The Product is only compatible with specific accessories and must not be combined with other sidewall solutions.
- 2.5 Intended for domestic use under normal conditions only.

Article 3 – Transport and Storage

- 3.1 Secure the Product properly during transport to prevent damage.
- 3.2 Always store and transport in the original packaging in a safe, dry environment.
- 3.3 Use only approved transport equipment suitable for the Product's weight.

Article 4 – Pre-Installation Check

- 4.1 Check all components for completeness and damage before installation.
- 4.2 Test components before mounting. If defects are suspected, stop installation and contact your supplier with photographic evidence.
- 4.3 Do not use or install the Product if any defects are detected. Use under these circumstances is at your own risk.

Article 5 – Installation

- 5.1 Ensure a safe work environment and remove all obstacles.
- 5.2 Installation requires at least two people.
- 5.3 Always use the prescribed bolts and screws.
- 5.4 Avoid placing fingers between wall profiles during assembly to prevent injury.
- 5.5 Ensure each panel is fully secured before adding another.
- 5.6 Do not disassemble or alter the Product beyond the scope of this manual.
- 5.7 Follow all tool safety instructions.
- 5.8 Wear safety shoes, protective eyewear, hearing protection and insulated gloves.

safety instructions
veiligheidsvoorschriften
sicherheitsvorschriften

- 5.9 Do not use sharp tools on or near the Product.
- 5.10 Do not install during strong winds.
- 5.11 Always follow the manuals provided with included parts.

Article 6 – Use and Safety

- 6.1 Keep small parts out of reach of children.
- 6.2 This Product is not a toy and not intended for use by children.
- 6.3 Avoid exposure to open flames.
- 6.4 Remove all packaging before use.
- 6.5 Do not use the Product during extreme weather such as strong winds, heavy snow, hail, earthquakes, lightning, or sandstorms.
- 6.6 If damage is suspected, take safety measures, vacate the area, and consult an expert.
- 6.7 Deactivate the Product and prevent further use if: visible damage is present
it no longer functions properly
it has been stored under adverse conditions
it has undergone heavy transport strain
- 6.8 Do not attach additional objects. Use only for its intended purpose.
- 6.9 It is your responsibility to assess or have assessed the required foundation. No advice is given regarding this.

Article 7 – Warranty and Liability

- 7.1 Deviations from the manual void the warranty and liability.
- 7.2 Do not attempt to repair the Product yourself.
- 7.3 Using non-original parts may void the warranty.
- 7.4 The manufacturer is not liable for property damage or consequential loss.
- 7.5 Technical specifications may change without prior notice.
- 7.6 All brand names and logos remain the property of their respective owners.
- 7.7 This manual is based on current regulations, standards, and practical expertise.
- 7.8 The general terms and applicable legal provisions at the time of purchase remain valid.

Following these instructions helps ensure safe and reliable use of the Product.

veiligheidsvoorschriften

2

Nederlands

Veiligheidsvoorschriften – Aluminium Wandsysteem

Artikel 1 – Algemene Bepalingen

- 1.1 Lees deze handleiding volledig door voordat u het aluminium wandsysteem (hierna: het 'Product') installeert of gebruikt. Onjuist gebruik kan leiden tot materiële schade of lichamelijk letsel, en doet de garantie vervallen.
- 1.2 Bewaar deze handleiding zorgvuldig en geef deze mee bij overdracht van het Product.
- 1.3 Neem bij vragen contact op met uw verkoopvertegenwoordiger. Schakel een professional in bij onvoldoende ervaring.
- 1.4 De afbeeldingen zijn informatief en kunnen afwijken van het werkelijke Product.
- 1.5 Deze handleiding is auteursrechtelijk beschermd en mag zonder schriftelijke toestemming niet worden gereproduceerd of verspreid.
- 1.6 Houd ongemonteerde onderdelen buiten bereik van kinderen.

Artikel 2 – Beoogd Gebruik

- 2.1 Het Product is een vaste aluminium wand, bedoeld voor montage aan de zijkant van een veranda.
- 2.2 Gebruik voor andere toepassingen is voor eigen risico. De fabrikant is in dat geval niet aansprakelijk voor eventuele schade.
- 2.3 De maximale windbelasting bedraagt 55,86 kg/m². Raadpleeg bij plaatsing in open gebieden een expert voor beoordeling van geschiktheid.
- 2.4 Het Product is alleen compatibel met specifieke accessoires en mag niet gecombineerd worden met andere zijwandoplossingen.
- 2.5 Uitsluitend ontworpen voor gebruik in huiselijke omgevingen onder normale omstandigheden.

Artikel 3 – Transport en Opslag

- 3.1 Zorg voor stevige bevestiging tijdens transport ter voorkoming van schade.
- 3.2 Bewaar en vervoer het Product in de originele verpakking op een veilige, droge locatie.
- 3.3 Gebruik enkel transportmiddelen die geschikt en goedgekeurd zijn voor het gewicht van het Product.

Artikel 4 – Controle Vooraf

- 4.1 Controleer vooraf op volledigheid en zichtbare schade.
- 4.2 Test onderdelen voor montage. Neem bij twijfel contact op met de leverancier en maak foto's van eventuele defecten.
- 4.3 Staak direct gebruik en installatie bij vermoeden van defect. Gebruik is in dat geval op eigen risico.

Artikel 5 – Installatie

- 5.1 Zorg voor een veilige werkomgeving en verwijder obstakels uit het werkgebied.
- 5.2 Minimaal twee personen zijn vereist voor een correcte installatie.
- 5.3 Gebruik altijd de voorgeschreven bout- en schroefverbindingen.
- 5.4 Vermijd het klemmen van vingers tussen wandprofielen; dit kan letsel veroorzaken.
- 5.5 Bevestig panelen stevig alvorens extra panelen toe te voegen.
- 5.6 Demontage of afwijkende montage is niet toegestaan.

- 5.7 Volg de instructies van alle gebruikte gereedschappen op.
- 5.8 Draag altijd veiligheidsschoenen, veiligheidsbril, gehoorbescherming en isolerende handschoenen.
- 5.9 Gebruik geen scherpe gereedschappen op het Product.
- 5.10 Installeer niet bij harde wind.
- 5.11 Volg de handleidingen van meegeleverde onderdelen strikt op.

Artikel 6 – Gebruik en Veiligheid

- 6.1 Houd kleine onderdelen buiten bereik van kinderen.
- 6.2 Het Product is geen speelgoed en niet bedoeld voor gebruik door kinderen.
- 6.3 Vermijd contact met vuur.
- 6.4 Verwijder alle verpakking vóór ingebruikname.
- 6.5 Gebruik het Product niet bij extreme weersomstandigheden zoals storm, sneeuw, hagel, aardbevingen, onweer of zandstorm.
- 6.6 Bij vermoeden van defect: direct veiligheidsmaatregelen nemen, het gebied ontruimen en een expert inschakelen.
- 6.7 Buiten gebruik stellen bij: zichtbare schade of vervorming
storingen of gebrekkige werking
langdurige ongunstige opslag
zware belasting tijdens transport
- 6.8 Bevestig geen externe objecten aan het Product. Alleen gebruiken waarvoor het ontworpen is.
- 6.9 Laat een deskundige beoordelen of en welke fundering noodzakelijk is.

Artikel 7 – Garantie en Aansprakelijkheid

- 7.1 Afwijkingen van de installatiehandleiding doen garantie en aansprakelijkheid vervallen.
- 7.2 Voer geen eigen reparaties uit.
- 7.3 Gebruik van niet-originele onderdelen kan de garantie ongeldig maken.
- 7.4 De fabrikant is niet aansprakelijk voor schade aan eigendommen of gevolgschade.
- 7.5 Technische specificaties kunnen zonder voorafgaande kennisgeving worden gewijzigd.
- 7.6 Merknamen en logo's blijven eigendom van de rechthebbenden.
- 7.7 Deze handleiding is opgesteld op basis van actuele regelgeving, technische normen en praktijkervaring.
- 7.8 De geldende algemene voorwaarden en wettelijke bepalingen op het moment van aankoop zijn van toepassing.

Door deze richtlijnen op te volgen, draagt u bij aan een veilige en duurzame werking van het Product.

safety instructions
veiligheidsvoorschriften
sicherheitsvorschriften

sicherheitsvorschriften

3 Deutsch

Sicherheitsvorschriften – Aluminium-Wandsystem

Artikel 1 – Allgemeine Bestimmungen

1.1 Lesen Sie dieses Handbuch vollständig durch, bevor Sie das Aluminium-Wandsystem (nachfolgend: das „Produkt“) installieren oder verwenden. Unsachgemäßer Gebrauch kann zu Sach- oder Personenschäden führen und die Gewährleistung ungültig machen.

1.2 Bewahren Sie das Handbuch sorgfältig auf und geben Sie es bei Weitergabe des Produkts mit.

1.3 Wenden Sie sich bei Fragen an Ihren Vertriebsmitarbeiter.

Ziehen Sie bei fehlender Erfahrung eine Fachkraft hinzu.

1.4 Abbildungen dienen der Veranschaulichung und können vom tatsächlichen Produkt abweichen.

1.5 Dieses Handbuch ist urheberrechtlich geschützt und darf ohne schriftliche Genehmigung nicht vervielfältigt oder verbreitet werden.

1.6 Halten Sie nicht montierte Komponenten von Kindern fern.

Artikel 2 – Bestimmungsgemäßer Gebrauch

2.1 Das Produkt ist eine feste Aluminiumwand zur seitlichen Montage an einer Terrassenüberdachung.

2.2 Die Verwendung für andere Zwecke erfolgt auf eigenes Risiko. Für daraus resultierende Schäden übernimmt der Hersteller keine Haftung.

2.3 Die maximale Windlast beträgt 55,86 kg/m². Lassen Sie die Eignung durch einen Fachmann prüfen, wenn das Produkt in offenen Bereichen aufgestellt wird.

2.4 Das Produkt ist nur mit bestimmten Zubehörteilen kompatibel und darf nicht mit anderen Seitenwandlösungen kombiniert werden.

2.5 Nur für den privaten Gebrauch unter normalen Bedingungen vorgesehen.

Artikel 3 – Transport und Lagerung

3.1 Sichern Sie das Produkt während des Transports ordnungsgemäß, um Schäden zu vermeiden.

3.2 Lagern und transportieren Sie das Produkt stets in der Originalverpackung an einem trockenen und sicheren Ort.

3.3 Verwenden Sie nur geeignete und zugelassene Transportmittel entsprechend dem Produktgewicht.

Artikel 4 – Kontrolle vor der Installation

4.1 Prüfen Sie vor der Installation auf Vollständigkeit und sichtbare Mängel.

4.2 Testen Sie die Teile vor der Montage. Bei Zweifeln kontaktieren Sie Ihren Lieferanten mit Fotodokumentation.

4.3 Bei vermutetem Defekt: Montage und Verwendung sofort unterbrechen. Nutzung auf eigenes Risiko.

Artikel 5 – Installation

5.1 Schaffen Sie eine sichere Arbeitsumgebung und entfernen Sie alle Hindernisse.

5.2 Für eine ordnungsgemäße Installation sind mindestens zwei Personen erforderlich.

5.3 Verwenden Sie nur die vorgeschriebenen Schraub- und

safety instructions
veiligheidsvoorschriften
sicherheitsvorschriften

Bolzenverbindungen.

5.4 Achten Sie darauf, keine Finger zwischen die Wandprofile zu klemmen.

5.5 Stellen Sie sicher, dass jedes Paneel fest verbunden ist, bevor Sie ein weiteres hinzufügen.

5.6 Demontage oder abweichende Montage ist nicht gestattet.

5.7 Beachten Sie die Sicherheitshinweise der Werkzeuge.

5.8 Tragen Sie Sicherheitsschuhe, Schutzbrille, Gehörschutz und isolierende Handschuhe.

5.9 Verwenden Sie keine scharfen Werkzeuge am Produkt.

5.10 Montieren Sie das Produkt nicht bei starkem Wind.

5.11 Folgen Sie den Anleitungen aller mitgelieferten Komponenten.

Artikel 6 – Verwendung und Sicherheit

6.1 Kleine Teile von Kindern fernhalten.

6.2 Das Produkt ist kein Spielzeug und nicht für Kinder bestimmt.

6.3 Vor offenem Feuer schützen.

6.4 Verpackung vor Inbetriebnahme vollständig entfernen.

6.5 Nicht bei extremen Wetterbedingungen verwenden (z. B. Sturm, Schnee, Hagel, Erdbeben, Blitz, Sandsturm).

6.6 Bei Verdacht auf Mängel: Schutzmaßnahmen treffen, Bereich räumen, Experten hinzuziehen.

6.7 Außerbetriebnahme erforderlich bei:

sichtbaren Schäden

Funktionsstörungen

unsachgemäßer Lagerung über längere Zeit

starker Transportbelastung

6.8 Befestigen Sie keine zusätzlichen Gegenstände. Verwenden Sie das Produkt nur bestimmungsgemäß.

6.9 Der Nutzer ist selbst dafür verantwortlich, die notwendige Fundamentierung prüfen oder prüfen lassen.

Artikel 7 – Garantie und Haftung

7.1 Abweichungen von der Anleitung führen zum Erlöschen von Garantie und Haftung.

7.2 Keine eigenständiger Reparaturen durchführen.

7.3 Die Verwendung nicht originaler Teile kann zum Verlust der Garantie führen.

7.4 Der Hersteller haftet nicht für Sach- oder Folgeschäden.

7.5 Technische Angaben können ohne vorherige Ankündigung geändert werden.

7.6 Alle Markenzeichen und Logos bleiben Eigentum der jeweiligen Inhaber.

7.7 Diese Anleitung basiert auf aktuellen Normen, technischen Standards und praktischer Erfahrung.

7.8 Es gelten die allgemeinen Geschäftsbedingungen und rechtlichen Bestimmungen zum Zeitpunkt des Kaufs.

Die Einhaltung dieser Vorschriften gewährleistet eine sichere und zuverlässige Nutzung des Produkts.

Legende

legenda / legenda / legende



wiederholen
repeat



geliefert
provided



erforderlich
required



optional
optional



Hinweis!
caution!



richtig
correct



falsch
wrong



Stahl
steel



Ziegel
brick



Holz
wood



Regenwasserablauf
rainwater drainage



Zu kaufen
to be purchased



im Karton geliefert
delivered in box



Experte kontaktieren
consult professional

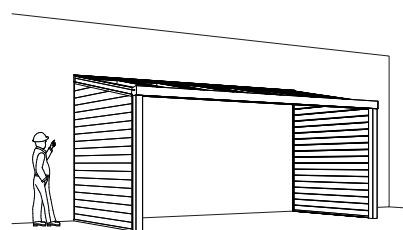

❌ 1

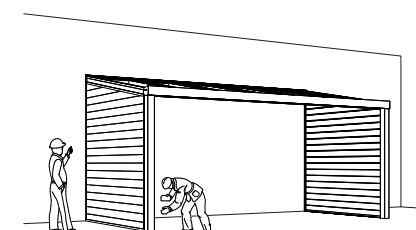

✅ 2

Werkzeuge

tools / gereedschap / werkzeuge

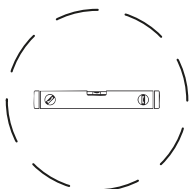
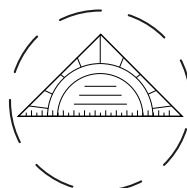
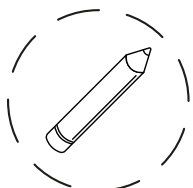
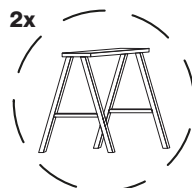
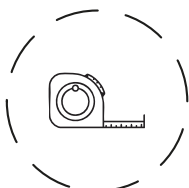
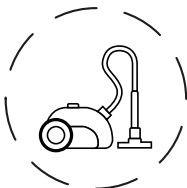
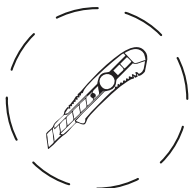
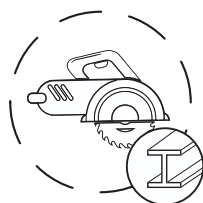
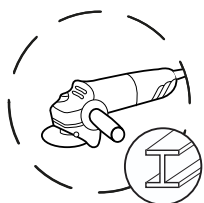
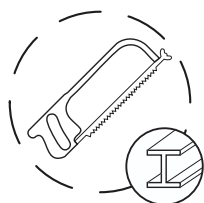
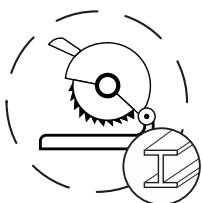

Teile

parts / onderdelen / teile

20LP42XXXX-X
4x

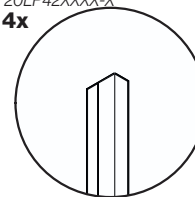

20FPL980-A/B
2x

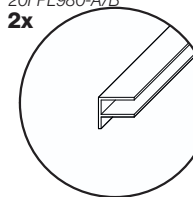

20PPXXXX-X

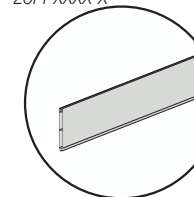

99T-A/B
20x

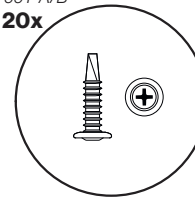

99TF3922
20x

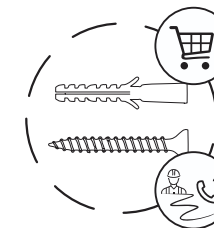
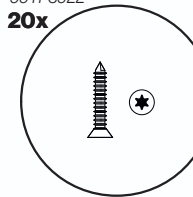

Konstruktion Übersicht

constructie overzicht/ konstruktionsübersicht

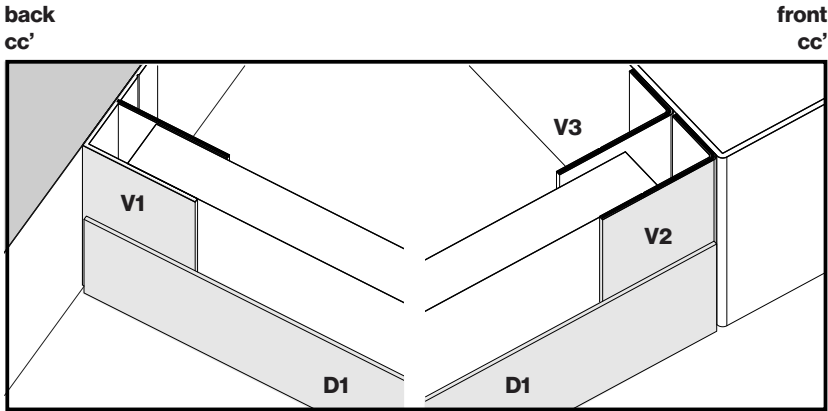
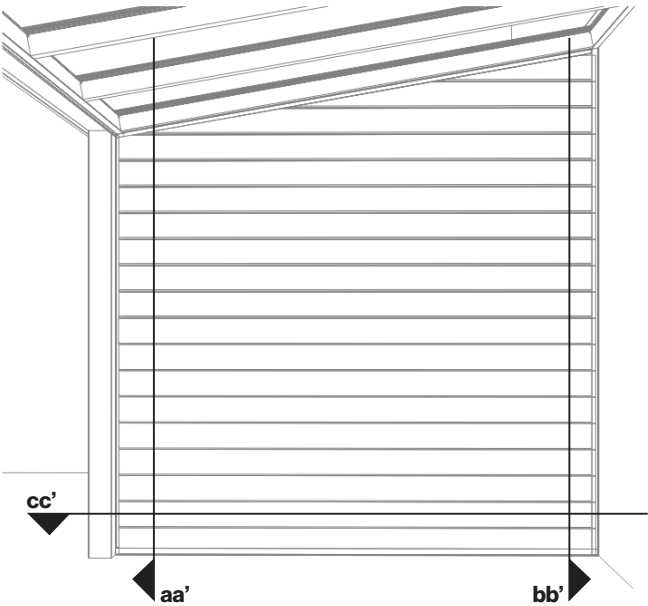

BEGHLER

Konstruktion Übersicht

constructie overzicht/ konstruktionsübersicht

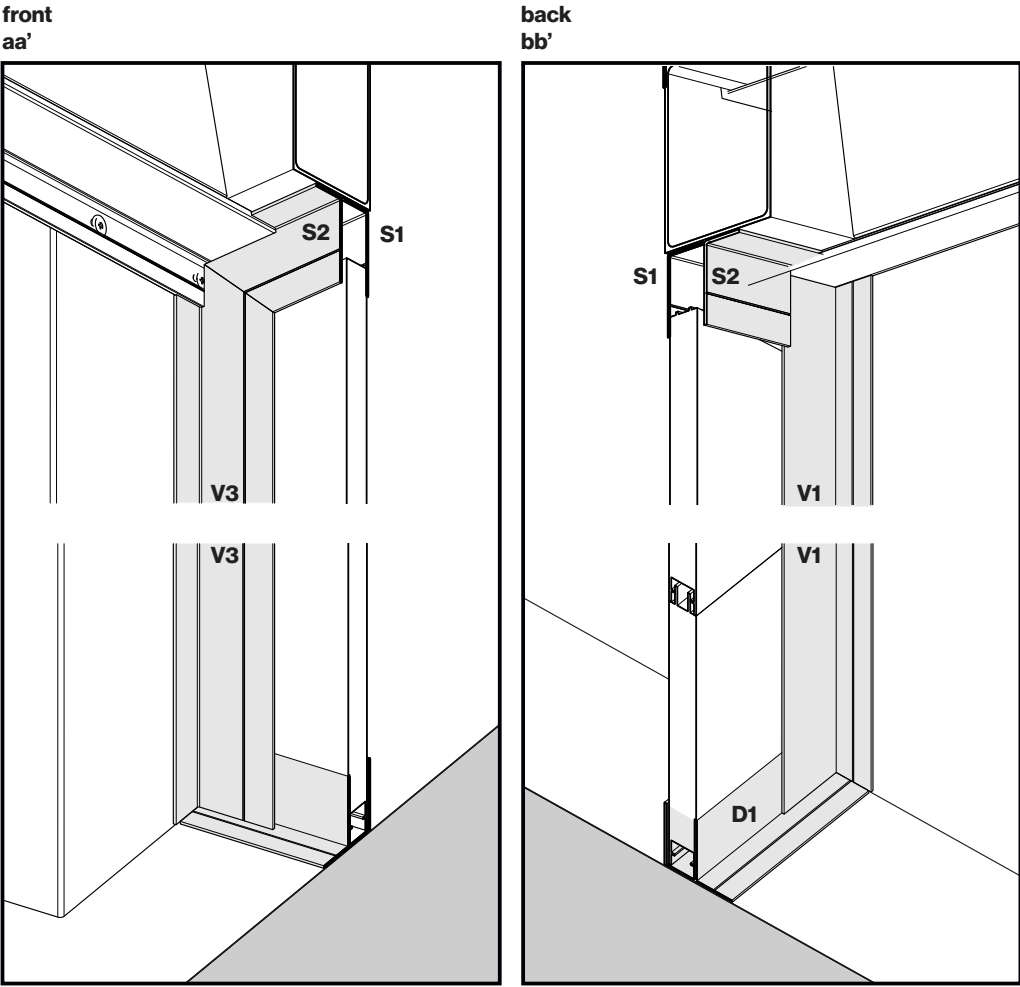

BEGHLER

1 Montage

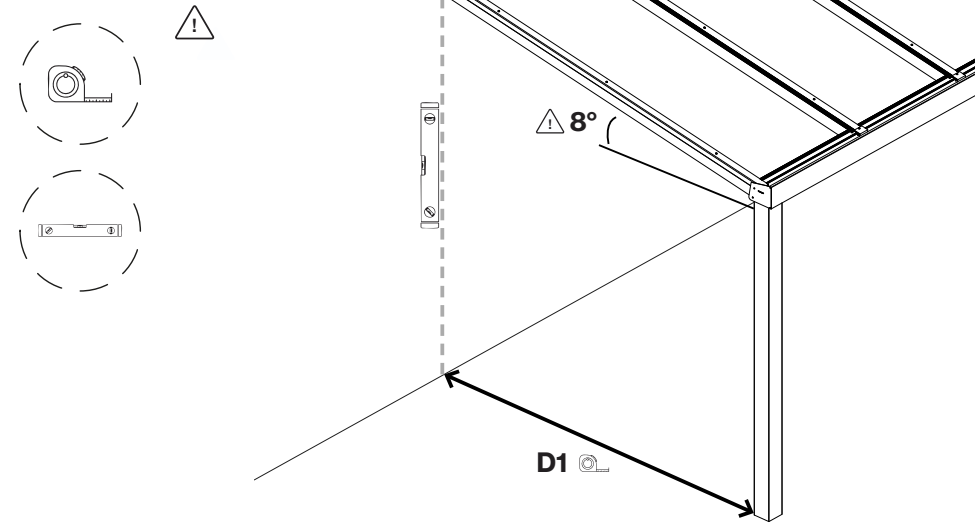

3

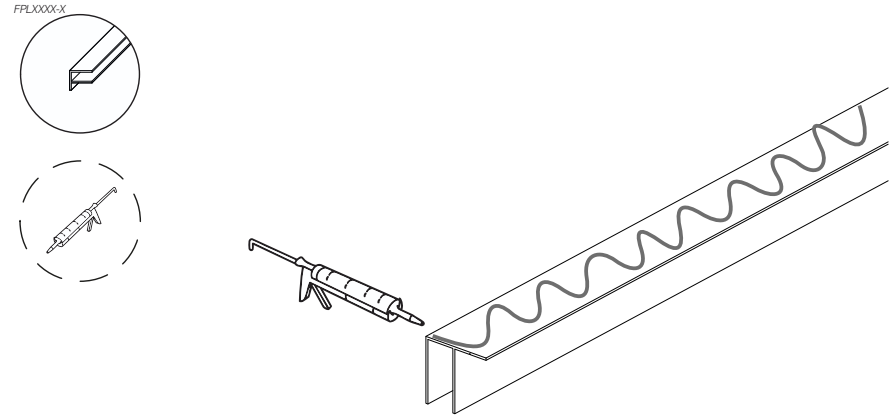

BEGHLER

2

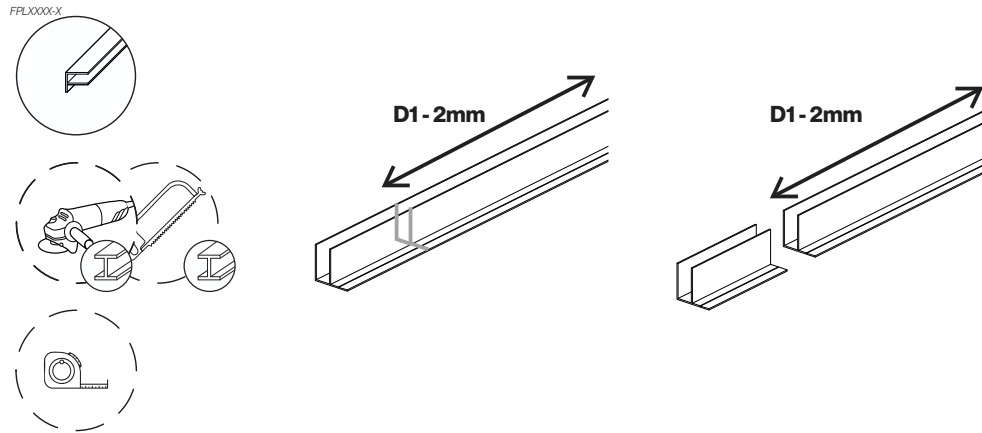

BEGHLER

BEGHLER

4

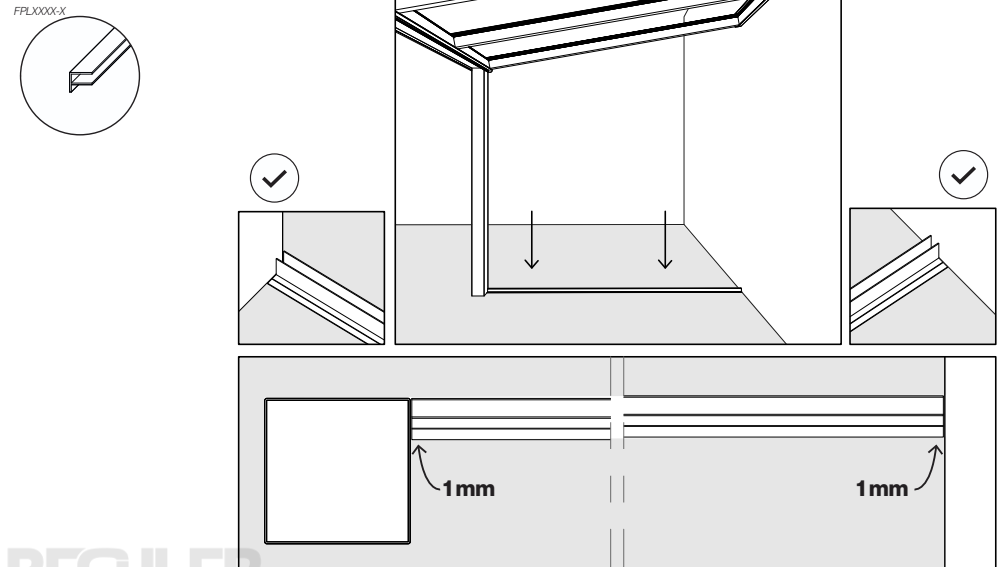

BEGHLER

5

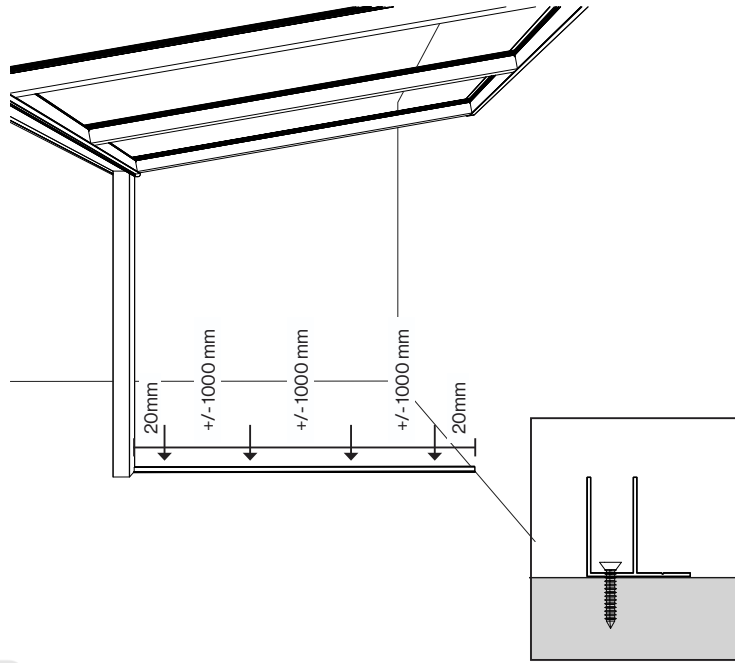
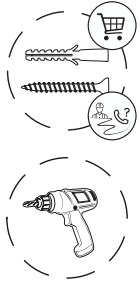

BEGHLER

7

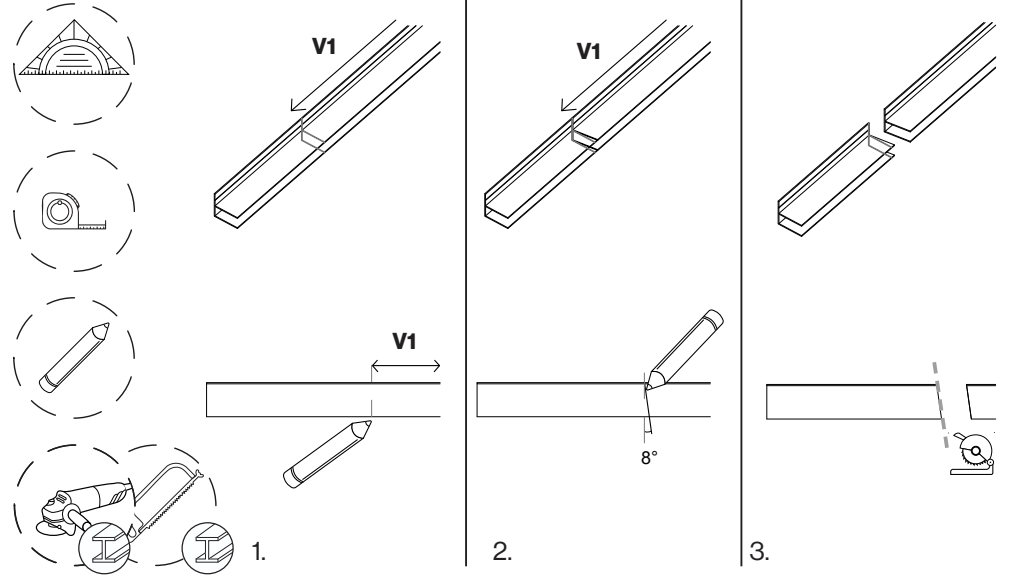

BEGHLER

6

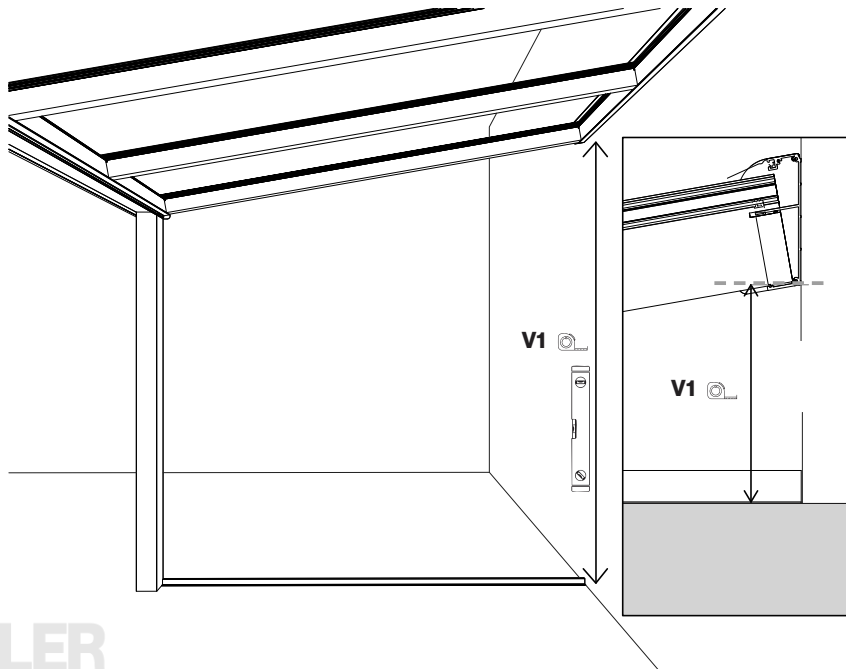
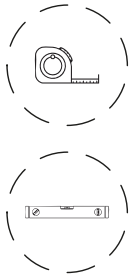

BEGHLER

8

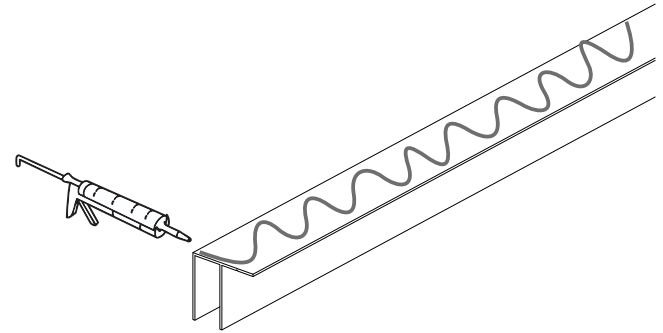
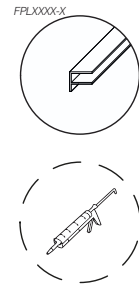

BEGHLER

9



FPLXXXX-X

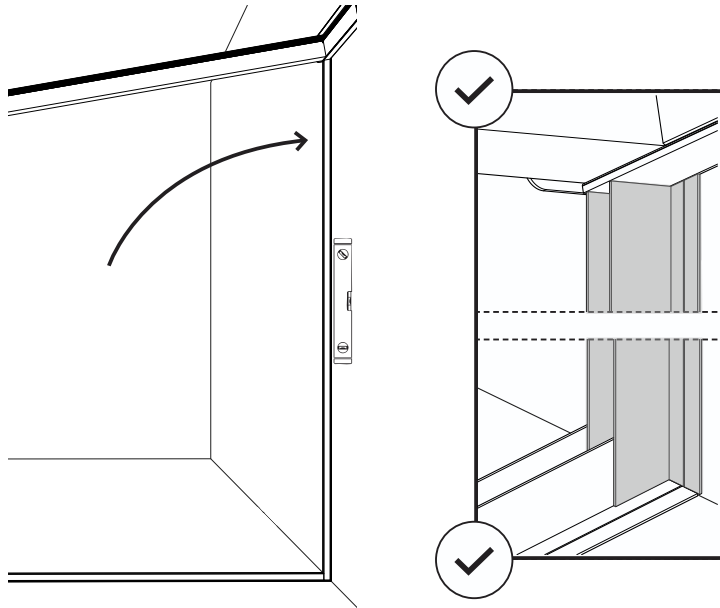

BEGHLER

10

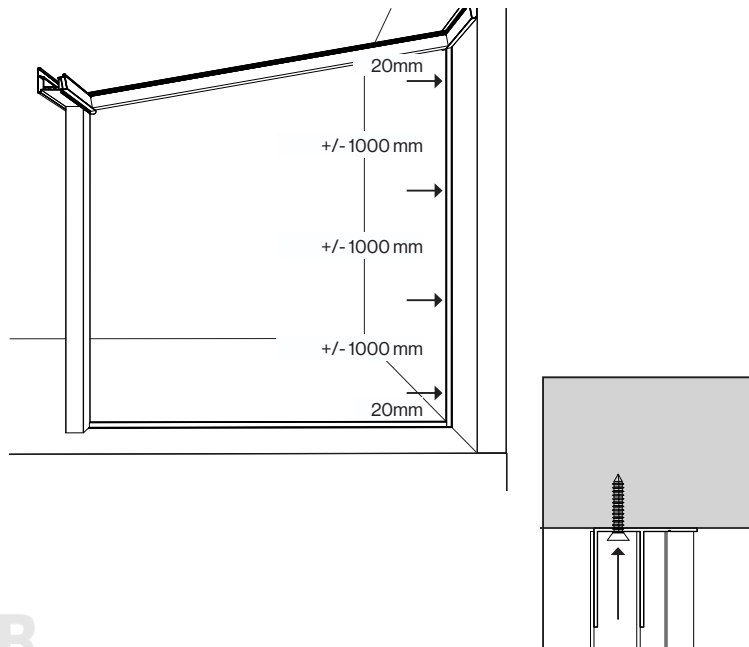
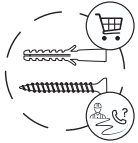

BEGHLER

11

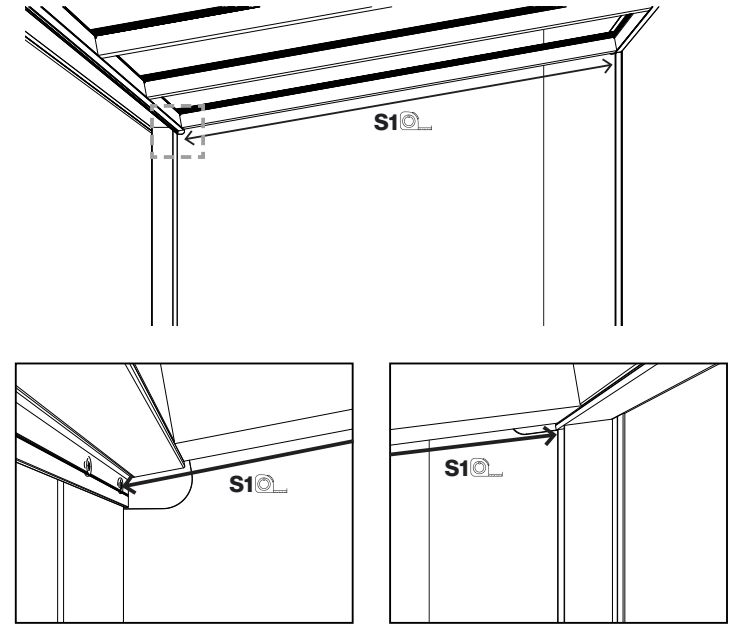
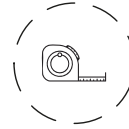

BEGHLER

12

20LP42XXXX-X

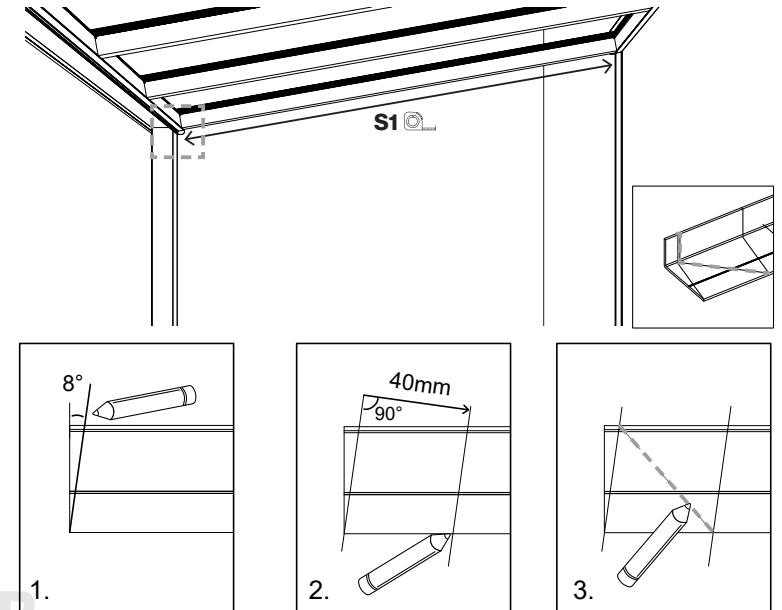
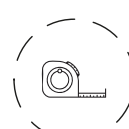
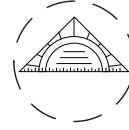

BEGHLER

13

20LP420000-X

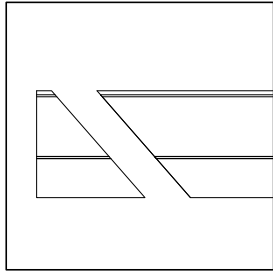
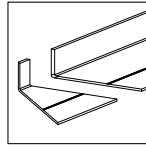
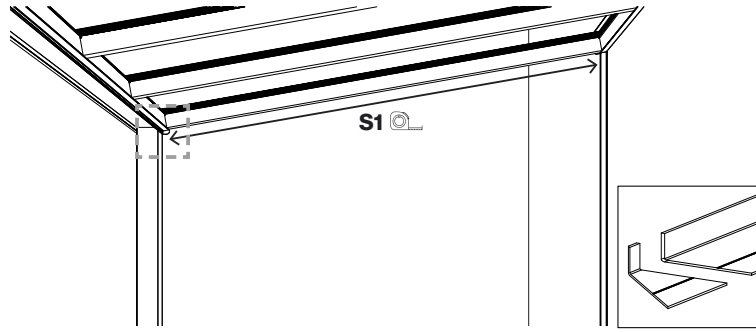
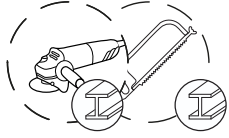

BEGHLER

15

20LP420000-X

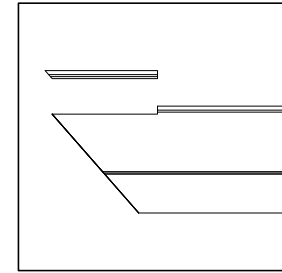
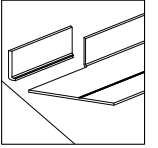
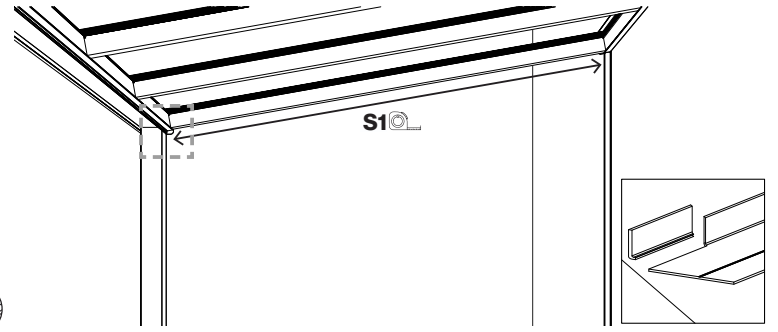
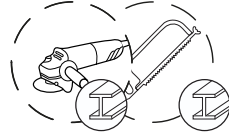

BEGHLER

14

20LP420000-X

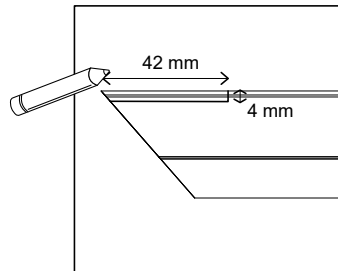
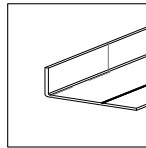

BEGHLER

16

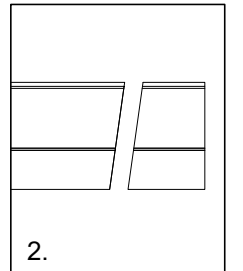
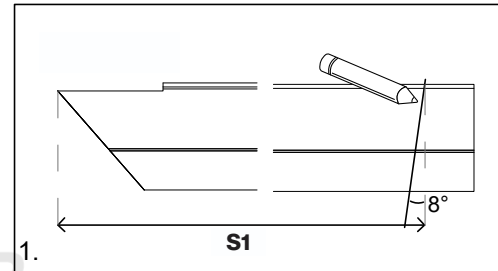
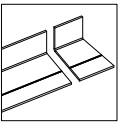
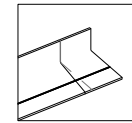
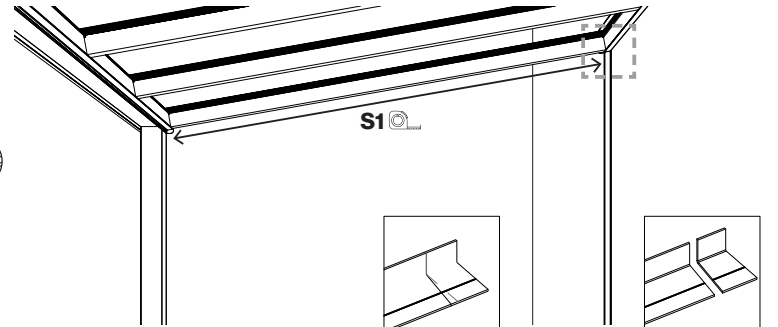
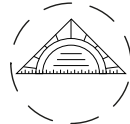
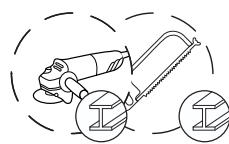

BEGHLER

17

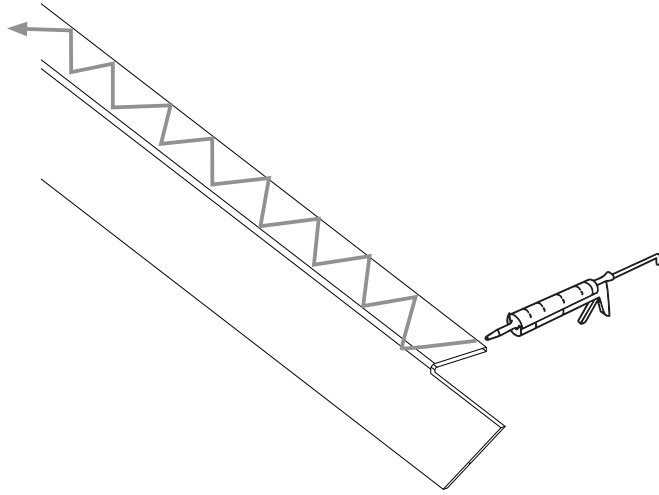

BEGHLER

18

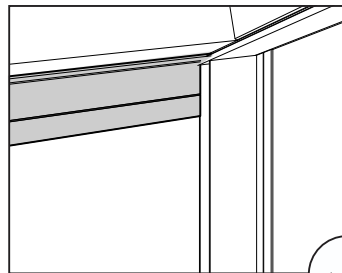
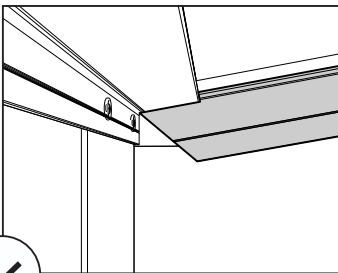
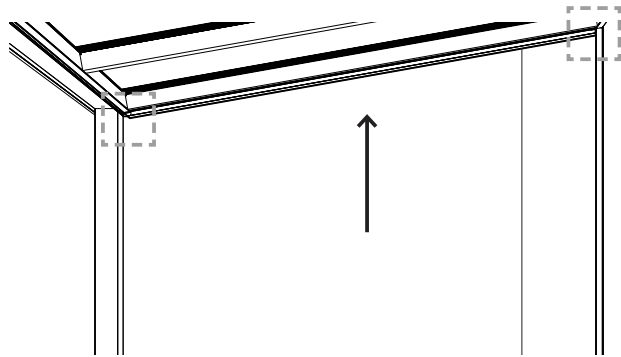

19

997F3922

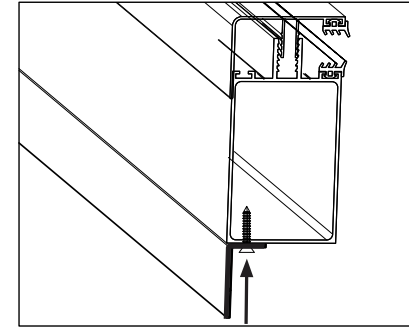
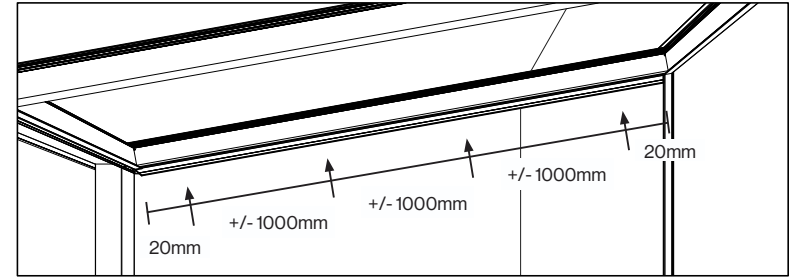
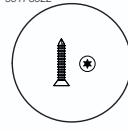

BEGHLER

20

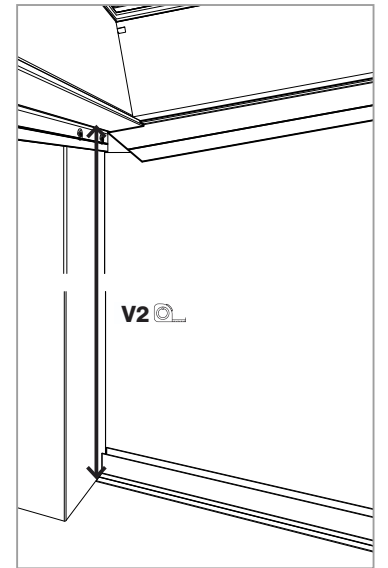
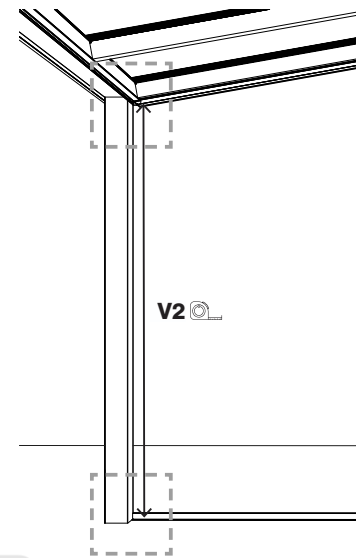
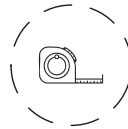

BEGHLER

BEGHLER

21

20LP420000-X

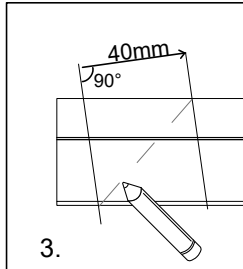
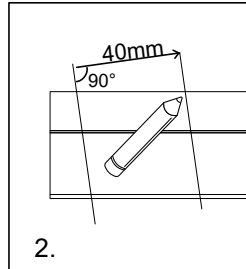
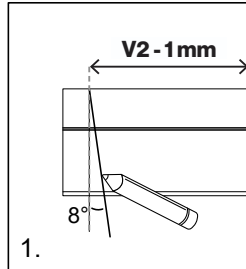
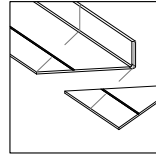
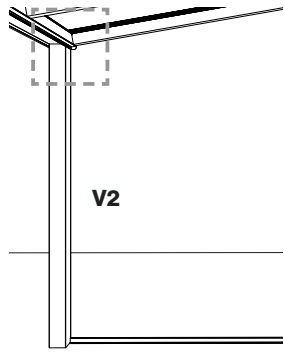
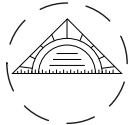
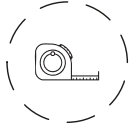

BEGHLER

22

20LP420000-X

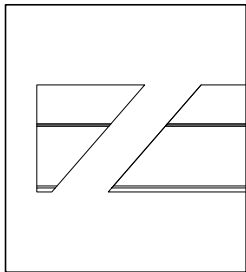
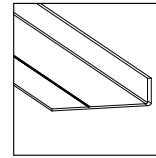
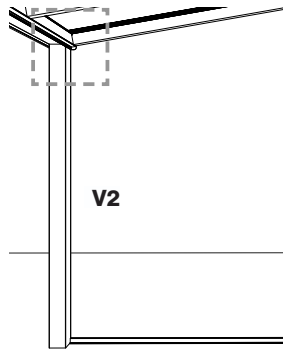
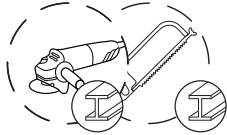

BEGHLER

23

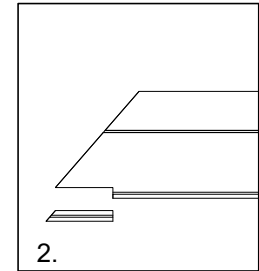
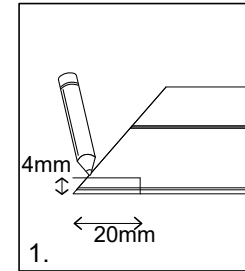
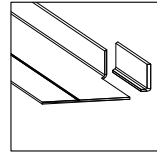
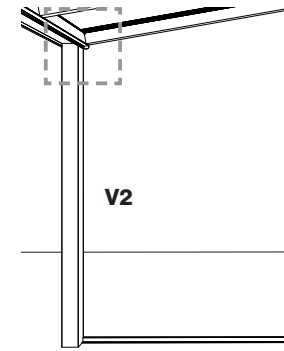
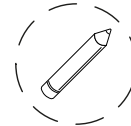
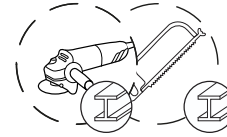

BEGHLER

24

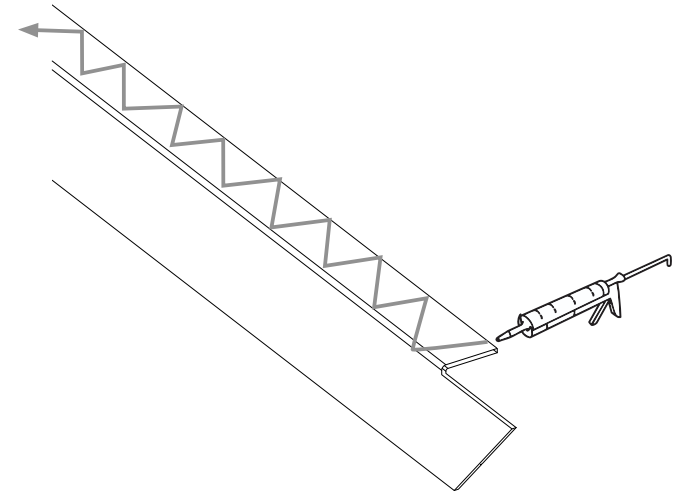

BEGHLER

25

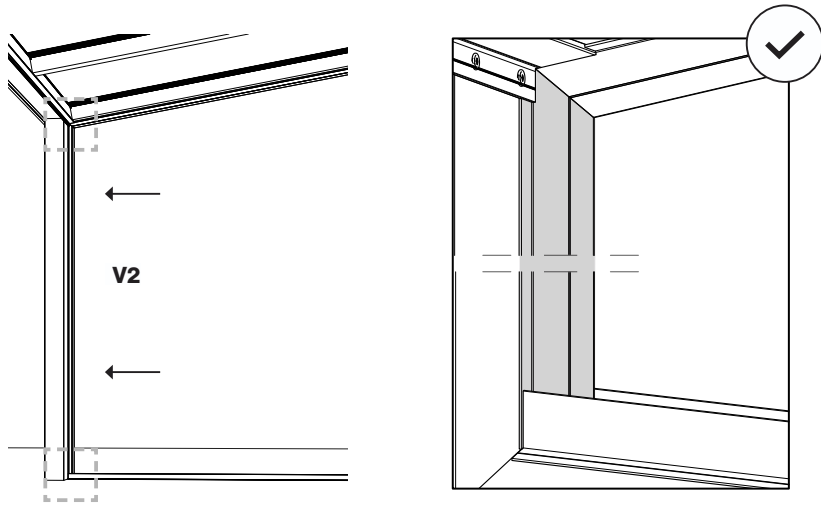

27

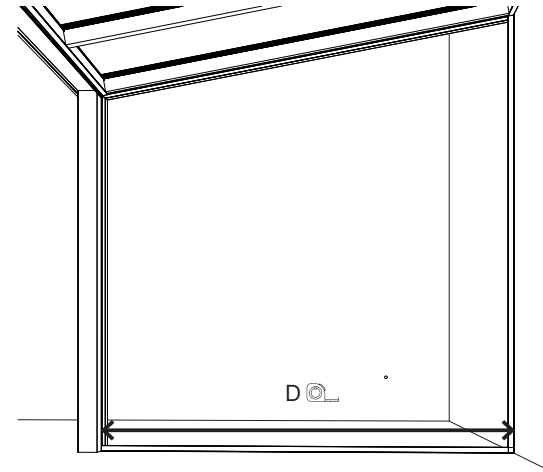

BEGHLER

BEGHLER

26

99TF3922

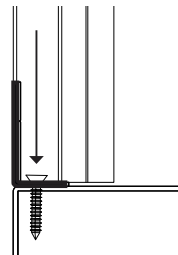
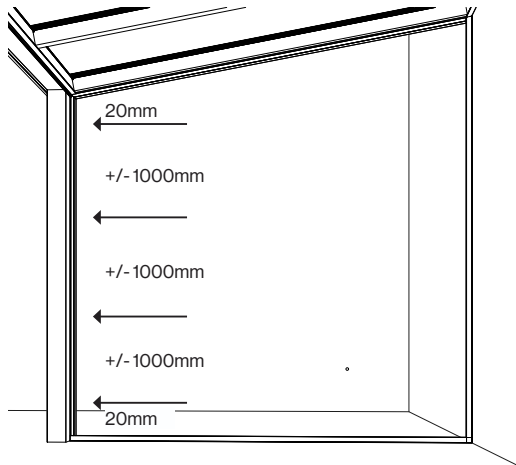
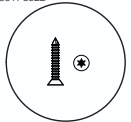

28



20PPXXXX-X

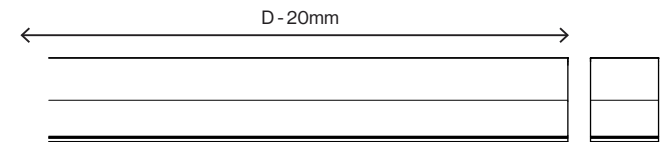
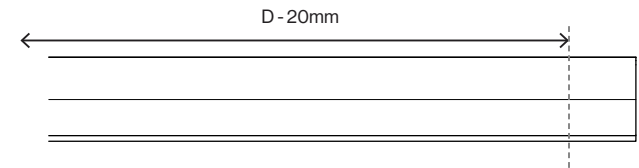
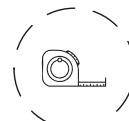
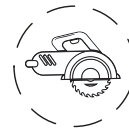
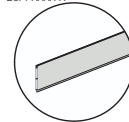

BEGHLER

BEGHLER

29



20PPXXXX-X

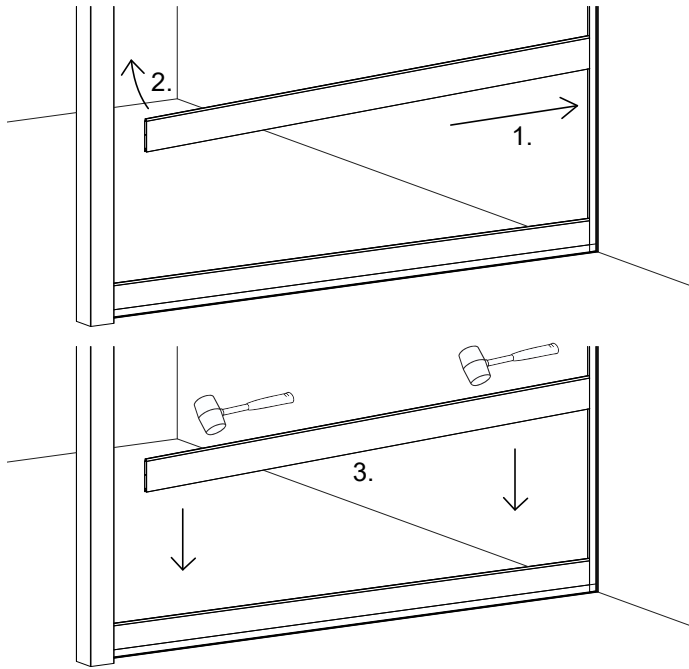
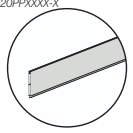

BEGHLER

30

20PPXXXX-X

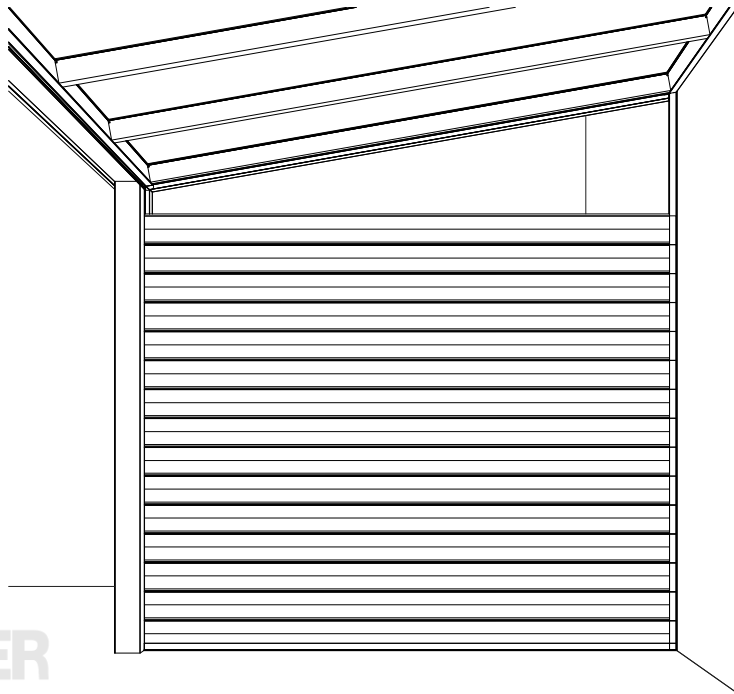
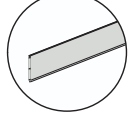

BEGHLER

31

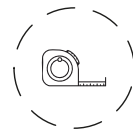

Y1 < 140 mm

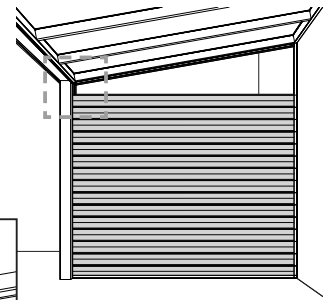
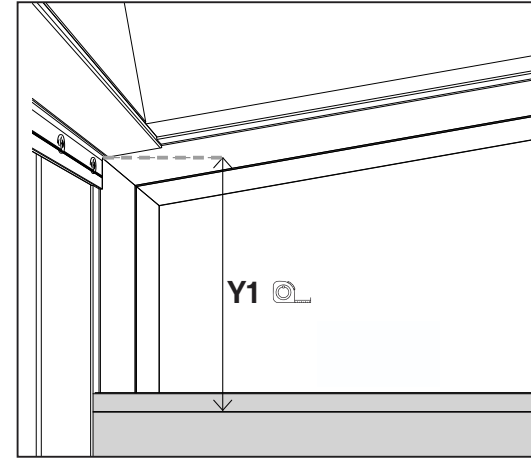

BEGHLER

32

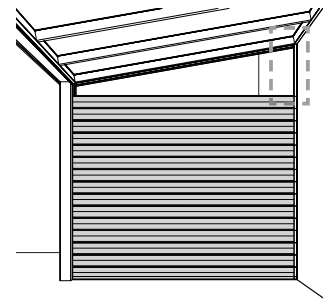
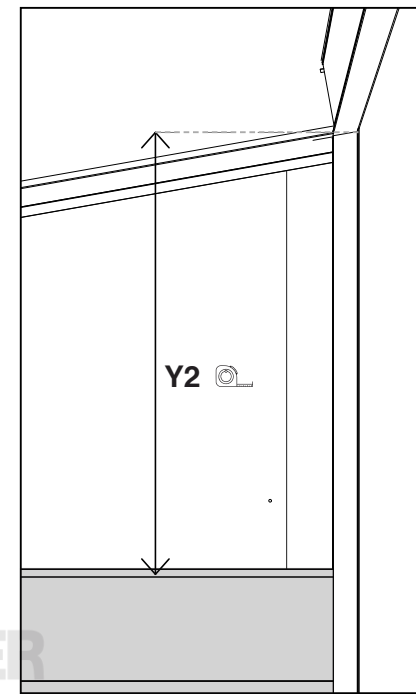
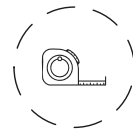

BEGHLER

33

20PPXXXX-X

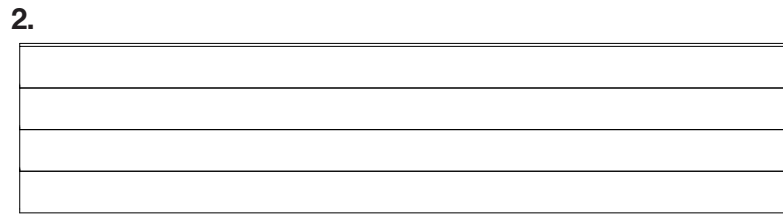
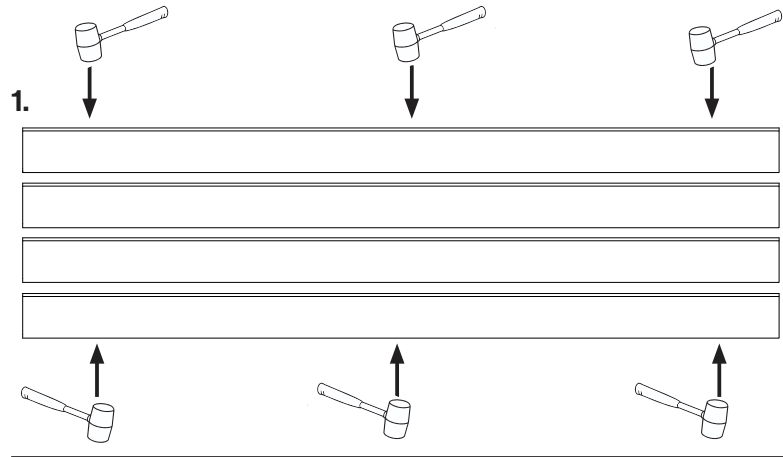
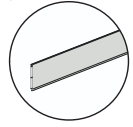

BEGHLER

34

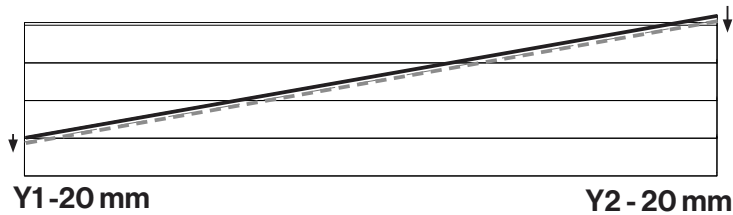
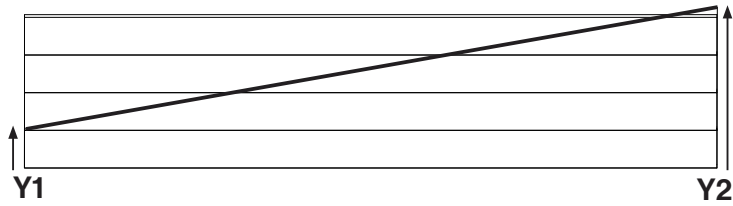
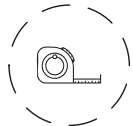

BEGHLER

35

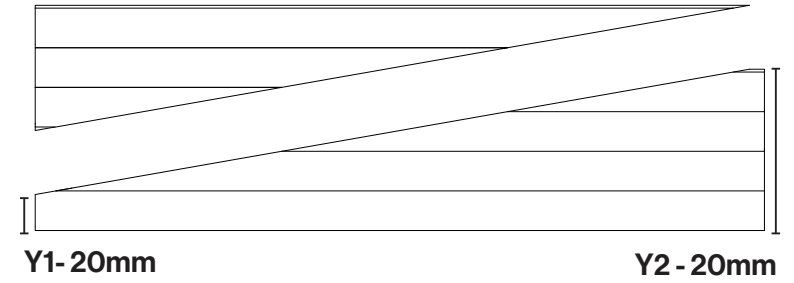
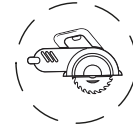

BEGHLER

36

20PPXXXX-X

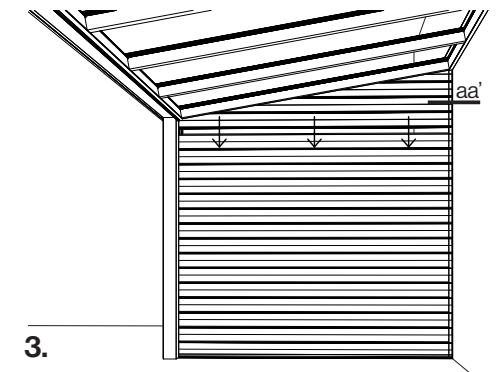
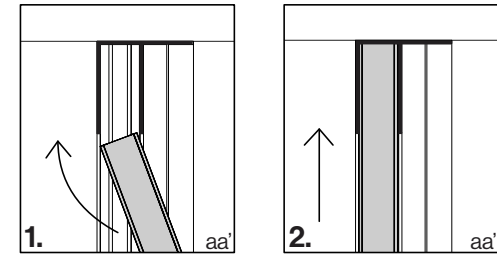
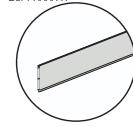

BEGHLER

37

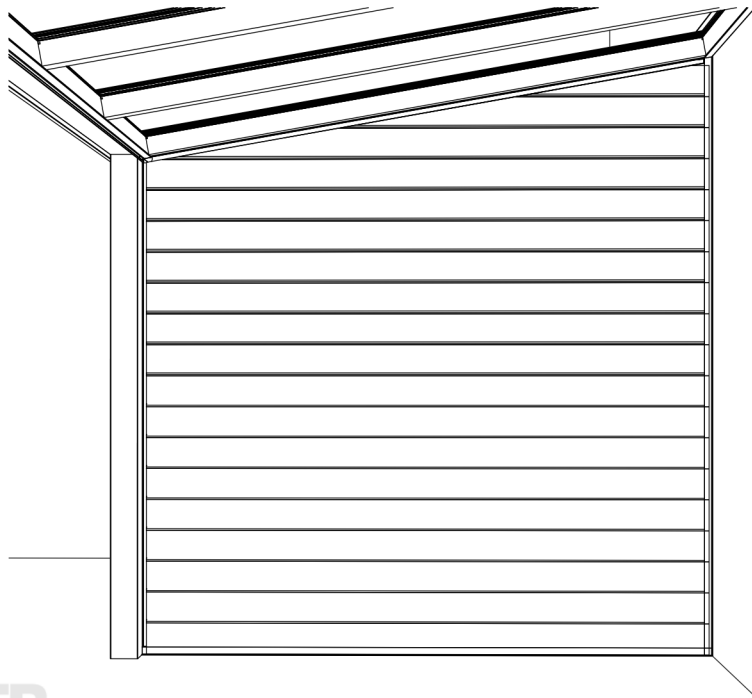

BEGHLER



11 - 16

38

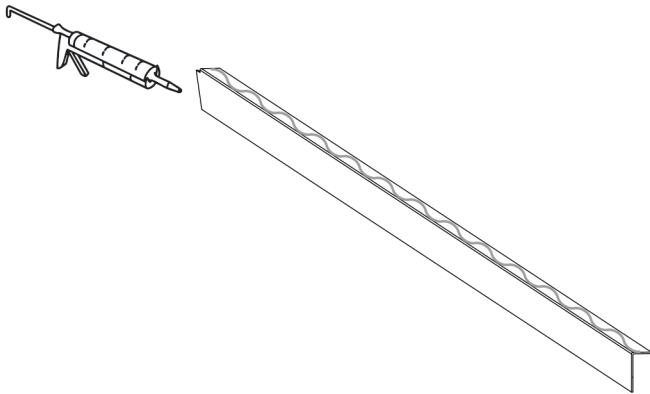

BEGHLER

30

39

20LP42000X

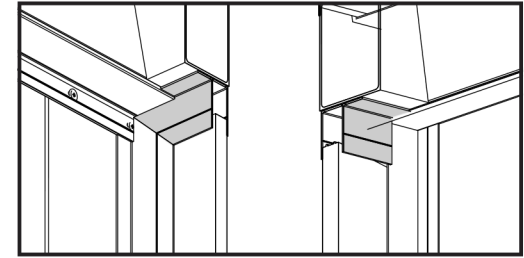
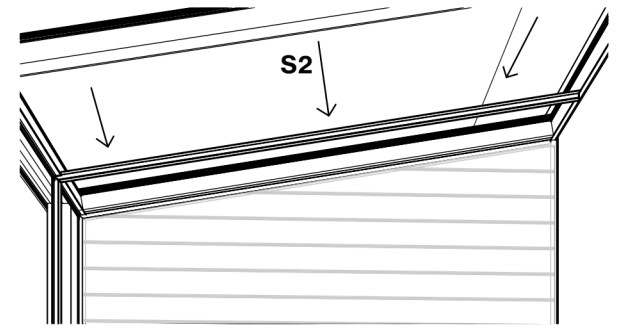
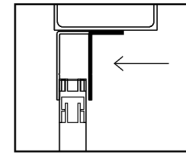

BEGHLER

40

99T-A/B

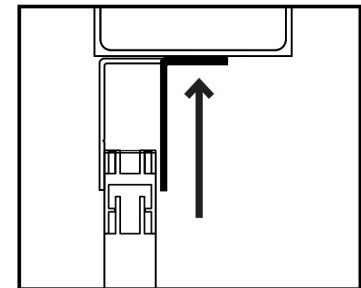
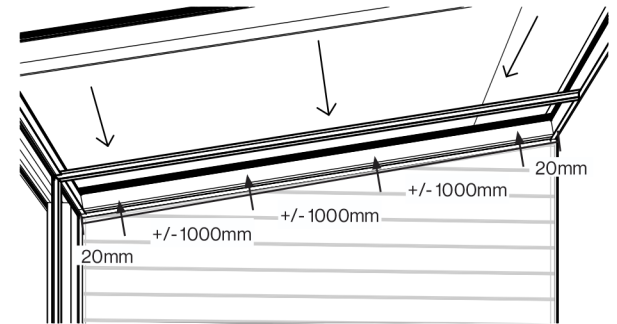

BEGHLER

31



41

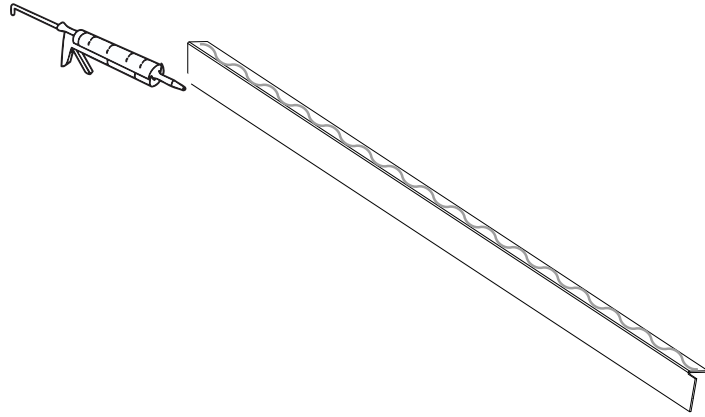
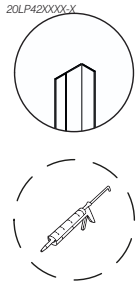

BEGHLER

42

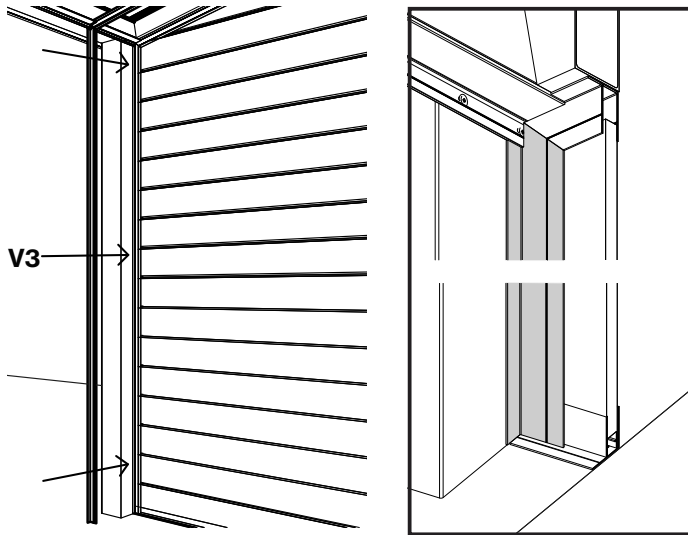
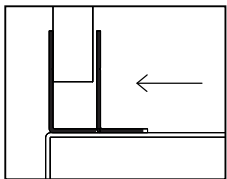

BEGHLER

43

99T-A/B

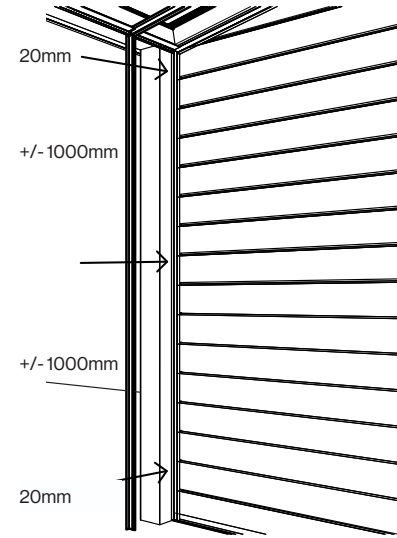
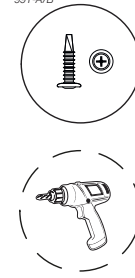

V3

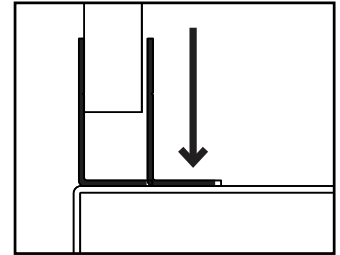

BEGHLER

44



mirror 1 - 42
for other side

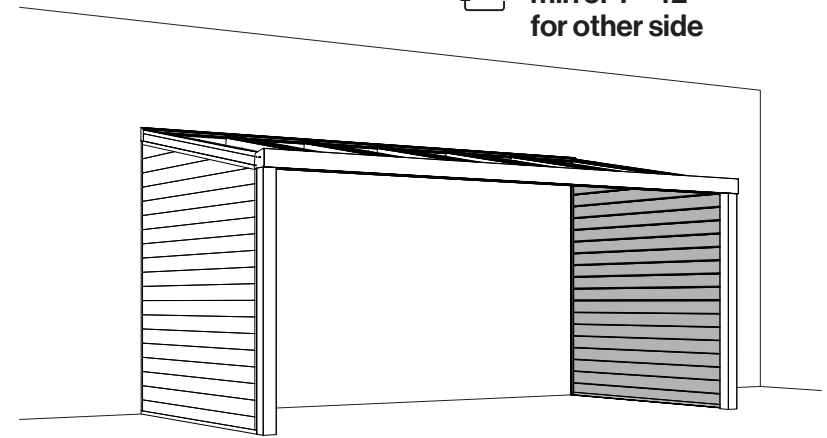

BEGHLER